

Load Control: Load Reactive Valves

NON-VENTED, 3:1, 1.5:1, 4.5:1 PILOT RATIOS

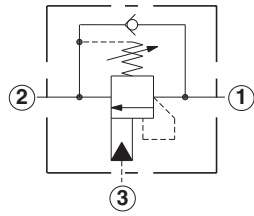
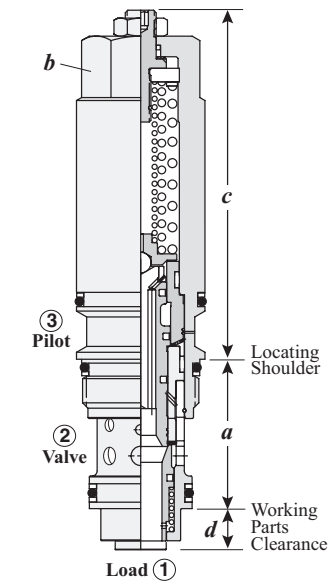

Capacity	Typical Cartridge Model Code	Cavity	Cartridge Dimensions				Installation Torque (Nm)
			a	b	c	d	
120 L/min.	MBEA – LHN	T-2A	35,1	28,6	92,7	7,1	60 - 70
240 L/min.	MBGA – LHN	T-17A	46,2	31,8	107,5	9,4	200 - 215
480 L/min.	MBIA – LHN	T-19A	63,5	41,3	124,0	5,8	465 - 500

Performance Curves

MBE*-L

MBG*-L

MBI*-L

Free Flow and Piloted Open Pressure Drop

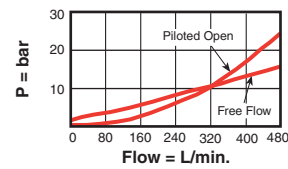
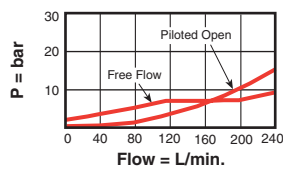
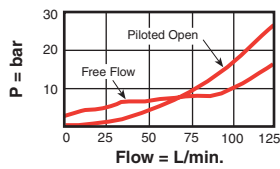

- Maximum recommended load pressure at maximum setting = 260 bar.
- Maximum setting = 350 bar.
- Factory pressure setting established at 30 cc/min.
- Maximum valve leakage at reseal = 0,3 cc/min.
- Reseat = >85% of set pressure.
- Reverse flow check cracking pressure = 2 bar.
- Load reactive load control valves should be set at least 1.3 times the maximum load induced pressure.
- Full clockwise lowest setting is 70 bar for the H range and 140 bar for the J range.
- Back pressure at port 2 adds to the effective relief setting at a ratio of 1 plus the pilot ratio times the back pressure.
- This valve is functionally a 3 port counterbalance valve. It seats as a poppet valve and modulates as a spool valve.

OPTION ORDERING INFORMATION

Nominal Capacity	Version	Control	Functional Setting Range	Seal Material
E 120 L/min.	A 3:1 Pilot Ratio	L Standard Screw Adjustment	H 70 - 280 bar Standard set at 210 bar	N Buna-N
G 240 L/min.	B 1.5:1 Pilot Ratio	MBEA, MBEB, MBEG only:	J 140 - 350 bar Standard set at 210 bar	V Viton
I 480 L/min.	G 4.5:1 Pilot Ratio	C* Tamper Resistant Factory Set		

* Special setting required. Specify at time of order.

Customer specified special setting stamped on hex.

Visit www.sunhydraulics.com for current list pricing and complete technical information on all Sun products.